

Two examples (Simple harmonic motion)

1. Spring & ball

2. Pendulum.

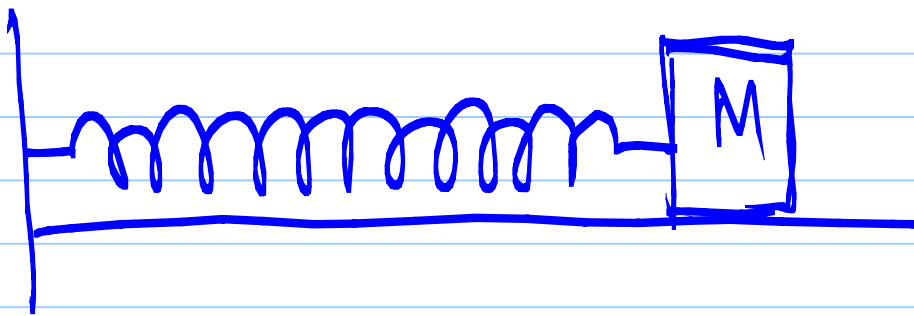

Spring & ball

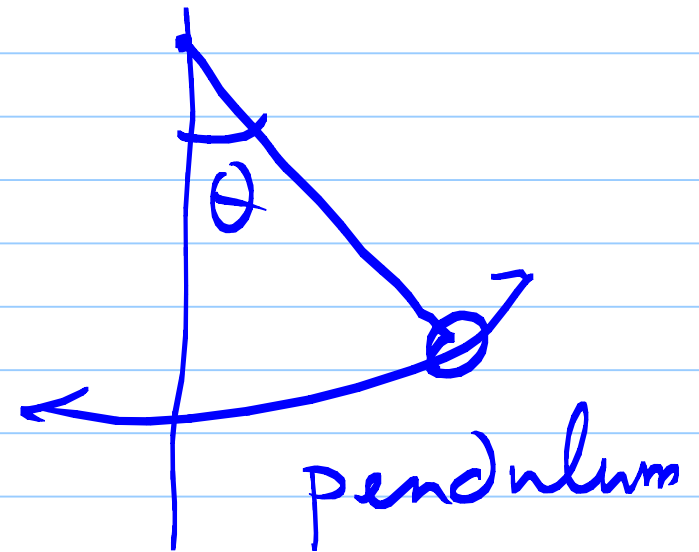

pendulum

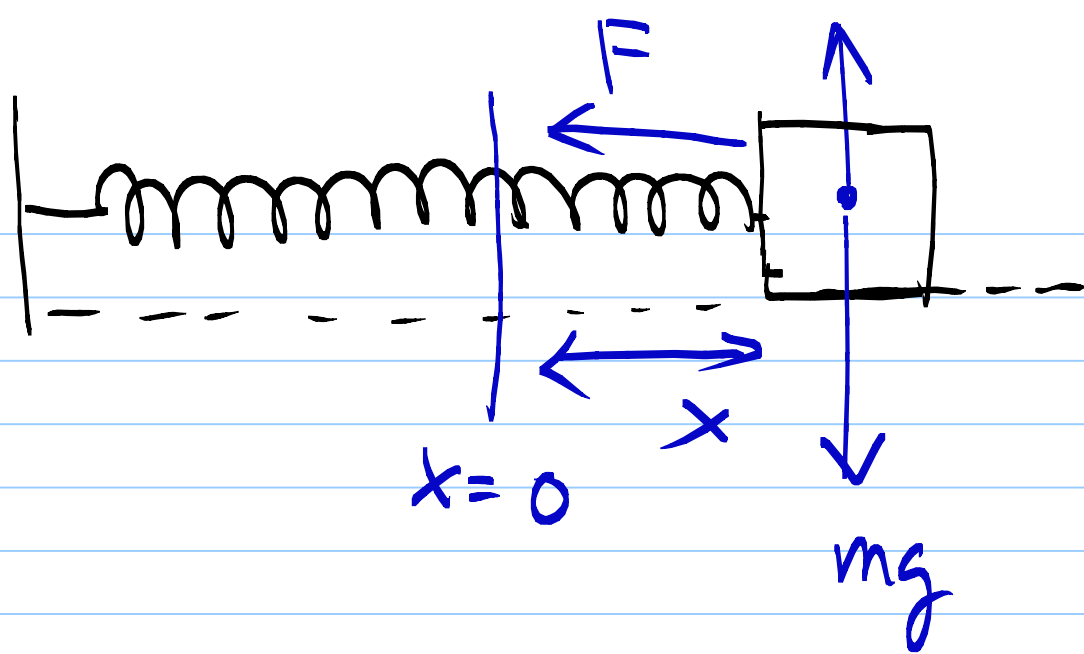

$$|F| \propto |x|$$

$$F = -kx$$

Restoring force

$k \rightarrow$ Spring Constant

Allow oscillation:

$$m\ddot{x} = -kx$$

$$m\ddot{x} + kx = 0$$

$$\ddot{x} + \frac{k}{m}x = 0$$

Period $T = \frac{2\pi}{\omega}$ (sec)

$$f = \frac{1}{T} \text{ Hz}$$

Angular frequency

$$x(t) = A \cos(\omega t + \phi)$$

\uparrow Amplitude
 \leftarrow phase

Calculate $\dot{x}(t) = -A\omega \sin(\omega t + \phi)$

$$\ddot{x}(t) = -A\omega^2 \cos(\omega t + \phi) = -\omega^2 x(t)$$

$$-\omega^2 x + \frac{k}{m} x = 0$$

$$\omega^2 = \frac{k}{m}$$

$$T = 2\pi \sqrt{\frac{m}{k}}$$

! Independent of
amplitude, phase

Phase \rightarrow Initial
Conditions

- * fixed position
- * initial velocity

Example

$$x=0, \quad t=0 \leftarrow \text{equilibrium!}$$

$$v = -3 \text{ m/s}$$

$$k = 10 \text{ N/m}, \quad m = 0.1 \text{ kg}$$

$$\omega = \sqrt{\frac{k}{m}} = 10 \text{ rad/s}, \quad T = 0.628 \text{ Sec}$$

$$f = 1.6 \text{ Hz.}$$

Initial condition!

$$x(t) = 0 = A \cos(\phi)$$

$$\cos \phi = 0$$

$$\phi = \frac{\pi}{2}, \quad \frac{3\pi}{2}$$

$$\dot{x} = -3 = -A \cdot 10 \cdot \sin \phi$$

$$\phi = \frac{\pi}{2} \rightarrow A = 0.3$$

$$\phi = \frac{3\pi}{2} \rightarrow A = -0.3$$

$$x(t) = \pm 0.3 \cos(10t + \frac{\pi}{2})$$

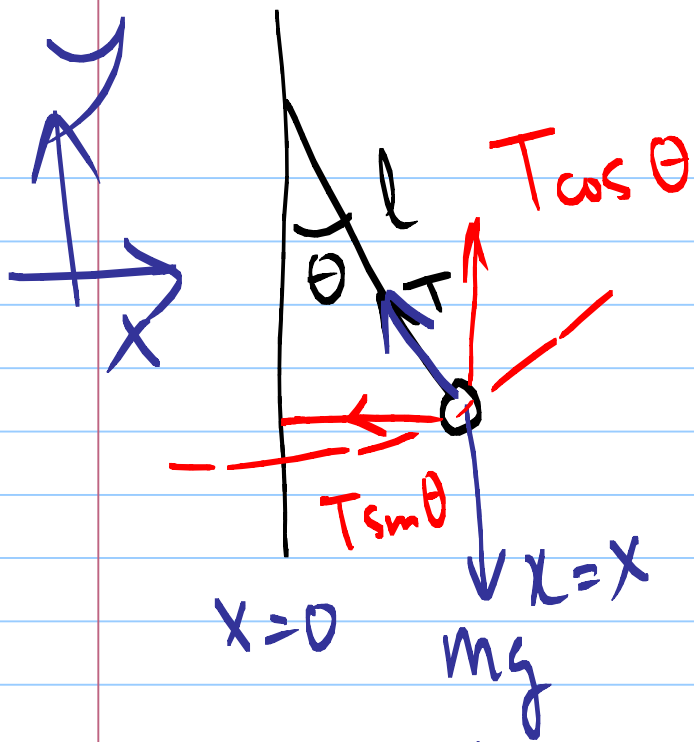

Eqⁿ of motion!

$$x: m \ddot{x} = -T(\theta) \sin \theta = -T(\theta) \frac{x}{l}$$

Restoring force!

$$y: m \ddot{y} = T(\theta) \cos \theta - mg$$

Take small angle approximation!

$$\textcircled{1} \quad \theta \ll 1 \text{ rad} \text{ --- small}$$

$$\cos \theta \sim 1$$

$$\left. \begin{aligned} \cos 5^\circ &= 0.996 \\ \cos 10^\circ &= 0.985 \end{aligned} \right\}$$

$$\textcircled{2} \quad \text{Displacement along } y \text{ --- small!}$$

$$\ddot{y} = 0$$

$$0 = T - mg \Rightarrow T = mg$$

$$m\ddot{x} + \frac{mg}{l}x = 0$$

$$\ddot{x} + \frac{g}{l}x = 0 \quad \underline{\underline{\sum H = 0}}$$

Solⁿ

$$x(t) = A \cos(\omega t + \phi)$$

$$\omega = \sqrt{\frac{g}{l}}, \quad T = 2\pi \sqrt{\frac{l}{g}}$$

Depends on l & g
does not depend on mass

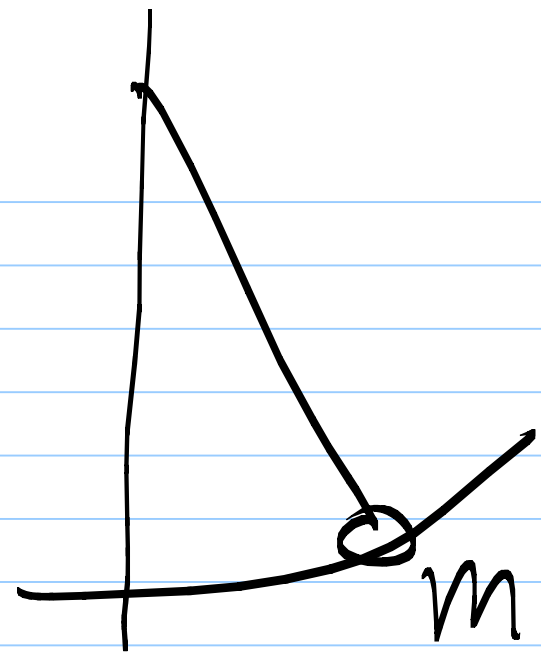
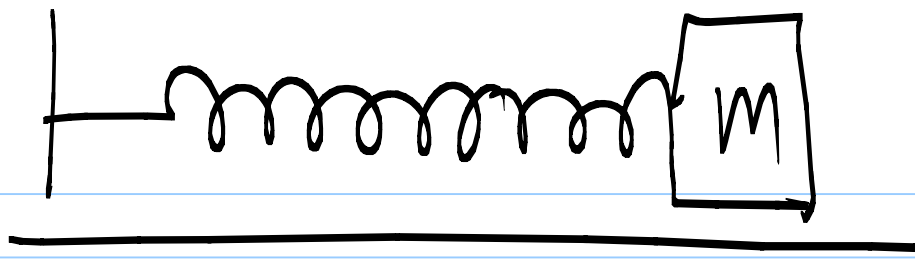

$$T = 2\pi \sqrt{\frac{m}{k}}$$

$$T = 2\pi \sqrt{\frac{l}{g}}$$

"Momentum"

Momentum

$$\vec{p} = m\vec{v}$$

kg m/s

$$\vec{F} = m\vec{a} = \frac{d}{dt}(m\vec{v}) = \frac{d\vec{p}}{dt}$$

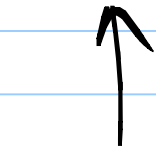

mass constant

$$\boxed{\vec{F} = \frac{d\vec{p}}{dt}}$$

— Newton's 2nd law!

Momentum \vec{p} is more fundamental than velocity!

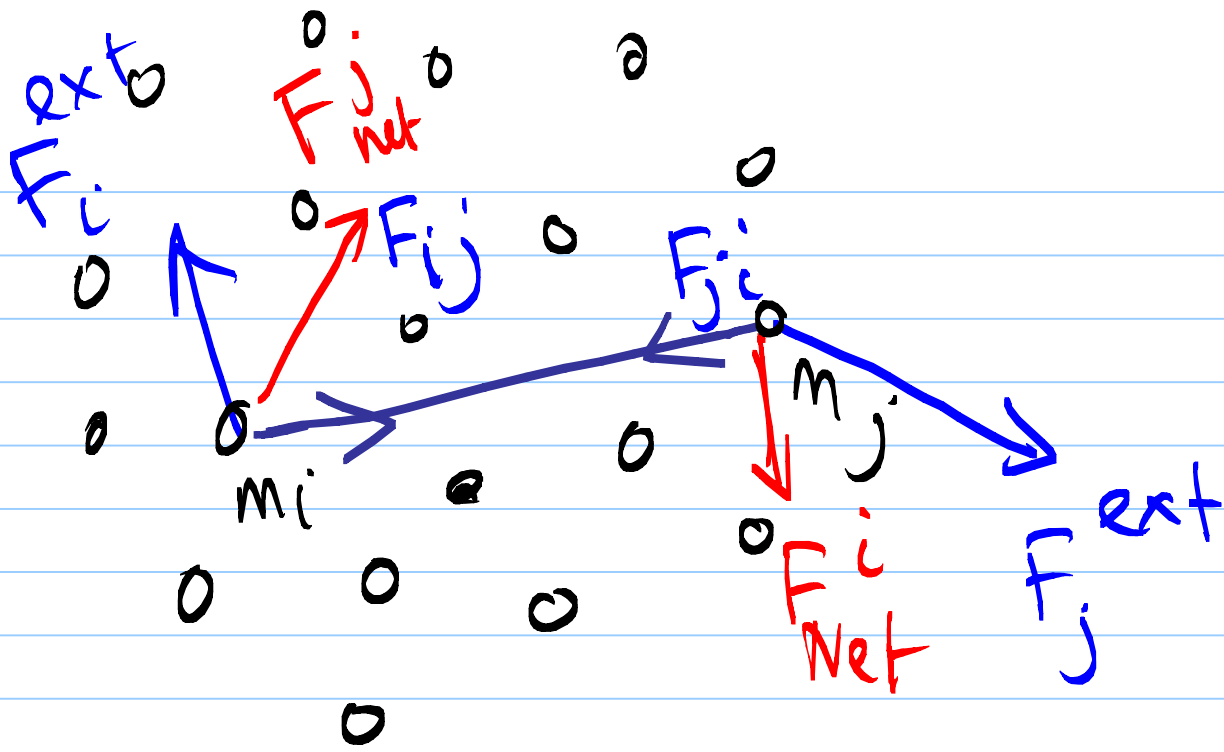

$$\vec{p}_{tot} = \vec{p}_1 + \vec{p}_2 + \vec{p}_3 + \dots + \vec{p}_i + \dots$$

$$\frac{d\vec{p}_{tot}}{dt} = \vec{F}_{Net}^1 + \vec{F}_{Net}^2 + \vec{F}_{Net}^3 + \dots + \vec{F}_{Net}^i + \dots$$

$$= \vec{F}_{tot} = \vec{F}_{int} + \vec{F}_{ext}$$

$$\vec{F}_{int} = 0 \quad [\text{by 3rd law}]$$

$$\frac{d\vec{p}_{\text{tot}}}{dt} = \vec{F}_{\text{ext}}$$

if $\vec{F}_{\text{ext}} = 0$

Momentum of the system is CONSERVED

Example:

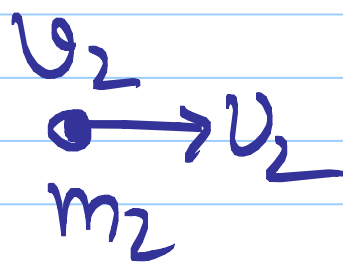
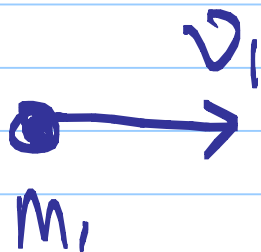

Before Collision

$$\vec{p} = m_1 \vec{v}_1 + m_2 \vec{v}_2$$

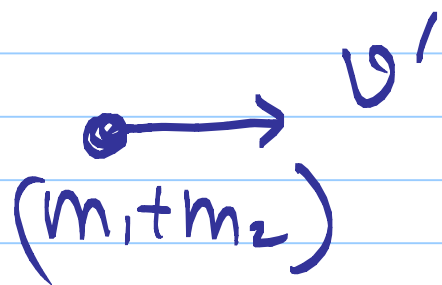

After Collision

$$\vec{p} = (m_1 + m_2) v'$$

$$m_1 = 1 \text{ kg} \\ m_2 = 2 \text{ kg}$$

$$v_1 = 5 \text{ m/s} \\ v_2 = 3 \text{ m/s}$$

Momentum Conservation \Rightarrow

$$5 \times 1 + 2 \times 3 = 11 = (1+2) v'$$

$$\Rightarrow v' = \frac{11}{3} \text{ m/s}$$

What happens to KE??

$$\text{KE. Before collision} = \frac{1}{2} m_1 v_1^2 + \frac{1}{2} m_2 v_2^2 = 21.5 \text{ J}$$

$$\text{KE. After " } = \frac{1}{2} (m_1 + m_2) v'^2 = 20.2 \text{ J}$$

$$m_1 = 1 \text{ kg}$$

$$v_1 = +5 \text{ m/s}$$

$$m_2 = 2 \text{ kg}$$

$$v_2 = -3 \text{ m/s}$$

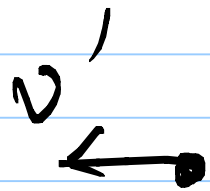
Before Collision

$$p_{\text{tot}} = 5 \times 1 - 3 \times 2 = -1 \text{ kg m/s}$$



$$(m_1 + m_2) v_1' = -1$$

$$v_1' = -\frac{1}{3} \text{ m/s}$$

$$\text{K.E After collision} = \frac{1}{2} \times 3 \times \left(\frac{1}{3}\right)^2 = \frac{1}{6} = 0.17 \text{ J}$$

K.E Destroyed !

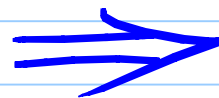
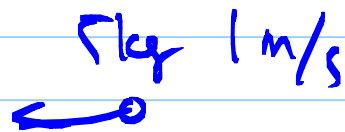
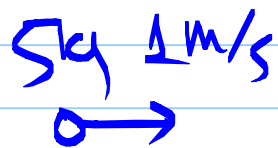

$$v = 0$$
$$\boxed{\text{K.E} = 0}$$

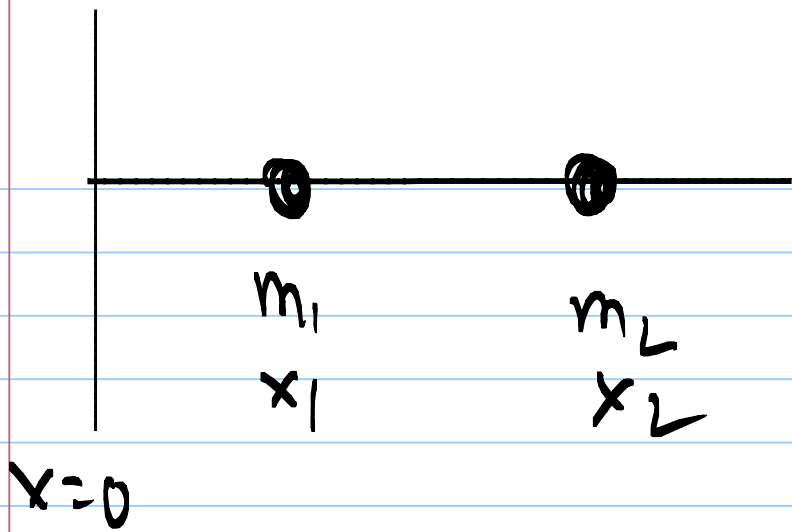

$$m_1 \ddot{x}_1 = \vec{F}_{12} + \vec{F}_{1, \text{ext}}$$

$$m_2 \ddot{x}_2 = \vec{F}_{21} + \vec{F}_{2, \text{ext}}$$

$$m_1 \ddot{x}_1 + m_2 \ddot{x}_2 = \vec{F}_{\text{ext}}$$

$$(m_1 + m_2) \frac{m_1 \ddot{x}_1 + m_2 \ddot{x}_2}{m_1 + m_2} = \vec{F}_{\text{ext}}$$

$$M \ddot{x}_{\text{CM}} = \vec{F}_{\text{ext}}$$

$$x_{\text{CM}} = \frac{m_1 x_1 + m_2 x_2}{m_1 + m_2}$$

Center of mass!

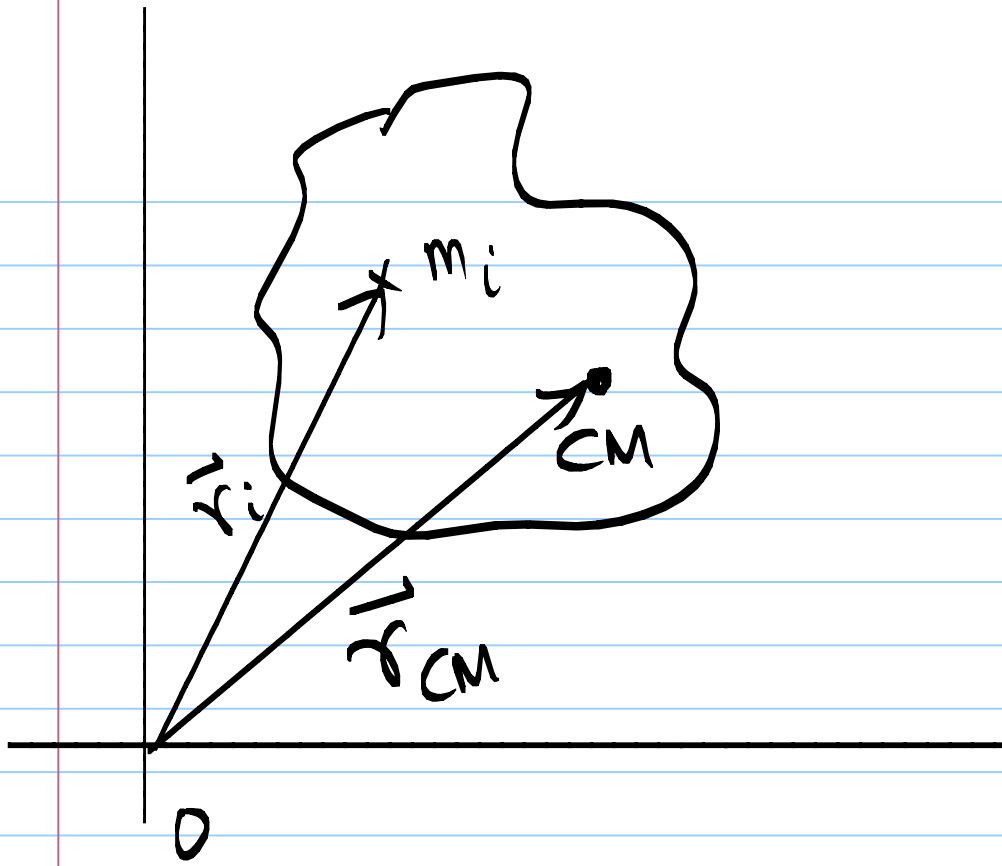

$$M_{tot} \vec{r}_{CM} = \sum_i m_i \vec{r}_i$$

$$\vec{v}_{CM} = \frac{1}{M_{tot}} \sum_i m_i \vec{v}_i$$

$$= \frac{1}{M_{tot}} \vec{p}_{tot}$$

$$\vec{p}_{tot} = M_{tot} \vec{v}_{CM}$$

$$\frac{d\vec{p}_{tot}}{dt} = M_{tot} \frac{d\vec{v}_{CM}}{dt} = M_{tot} \vec{a}_{CM}$$

Center of mass

$$\vec{R} = \frac{m_1 \vec{r}_1 + m_2 \vec{r}_2}{m_1 + m_2}$$

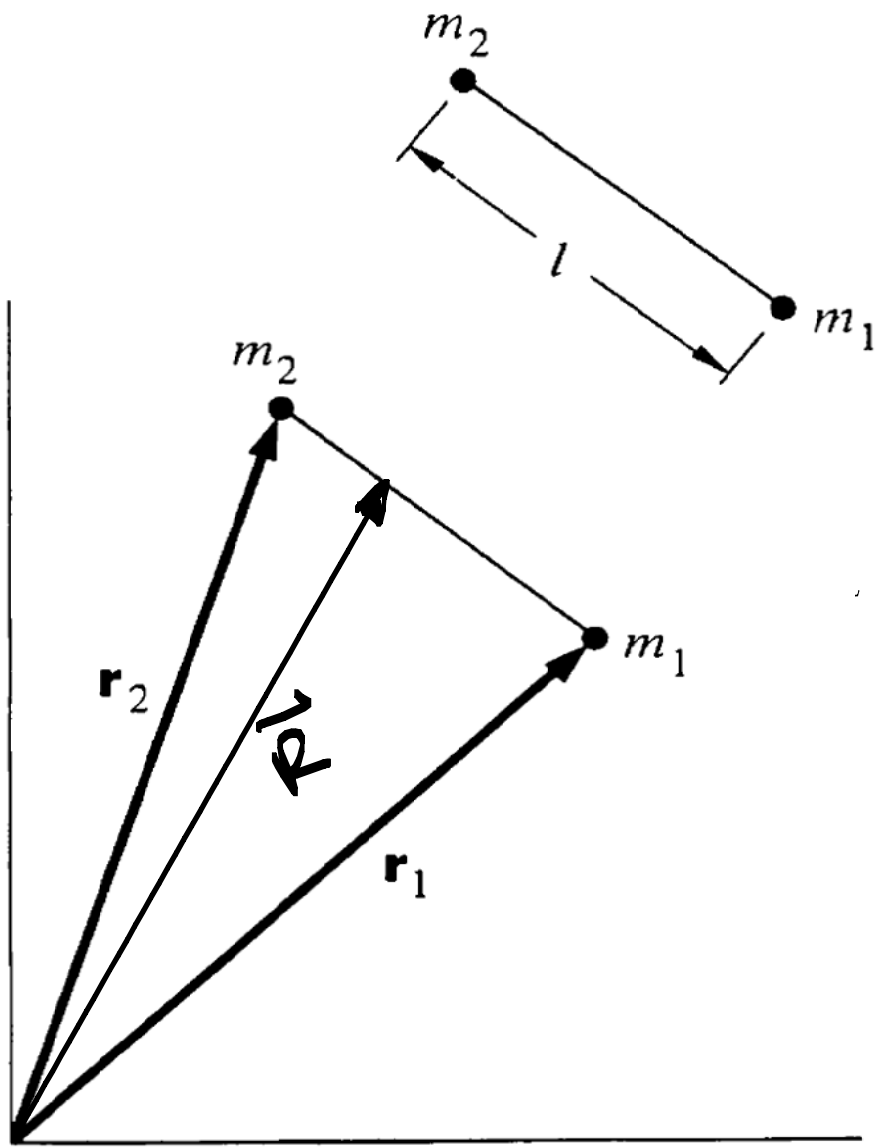

Neglect the mass of
thin rod!

Baton is thrown into air!

What is eqnⁿ of motion?

External force on the baton is

$$\vec{F} = m_1 \vec{g} + m_2 \vec{g}$$

$$(m_1 + m_2) \vec{R} = (m_1 + m_2) \vec{g}$$

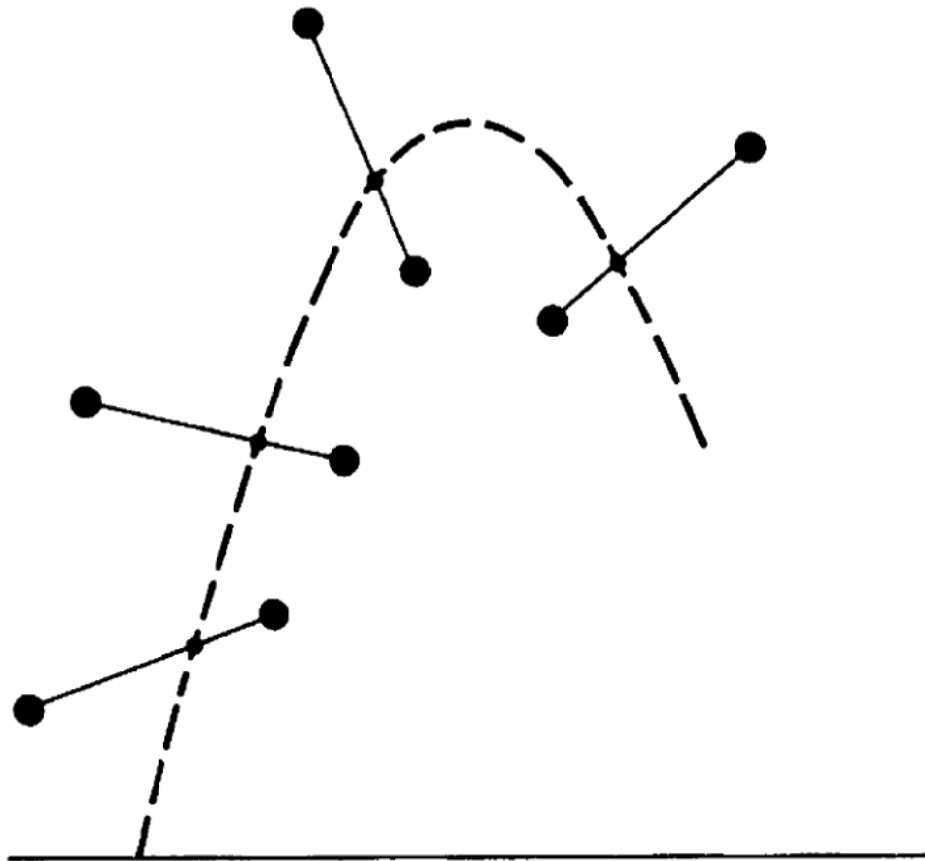

$$\vec{R} = \vec{g}$$

→ motion under gravitation force of a single object.

Center of mass of an extended object

$$\vec{R} = \frac{1}{M} \sum_{j=1}^N m_j \vec{r}_j$$

$N \rightarrow \infty$ for extended object

$$\vec{R} = \frac{1}{M} \int \vec{r} dm$$

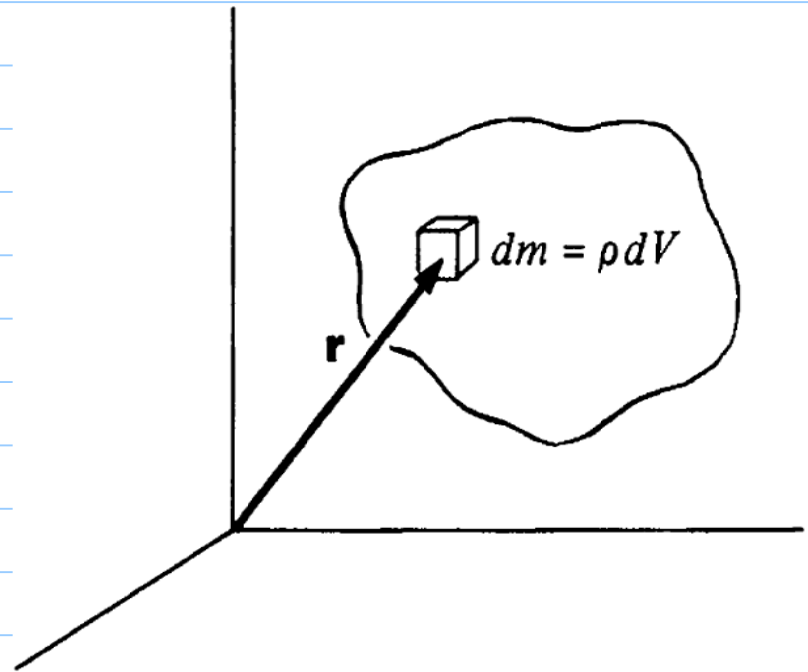

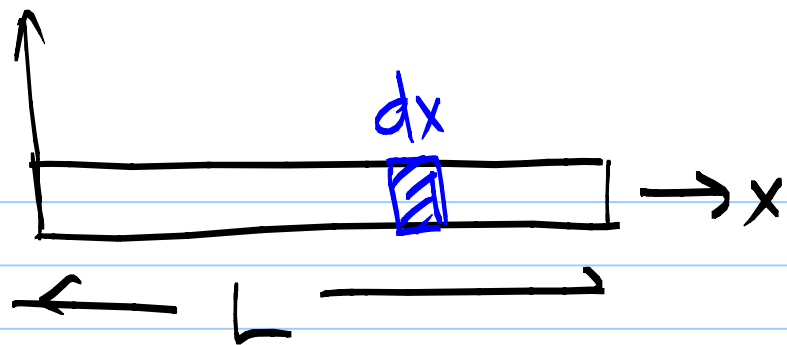

mass M
Length L

$$R = \frac{\int x dm}{M} = \frac{\int x \frac{M}{L} dx}{M}$$

$$= \frac{1}{L} \int_0^L x dx = \frac{1}{L} \cdot \frac{L^2}{2} = \frac{L}{2}$$

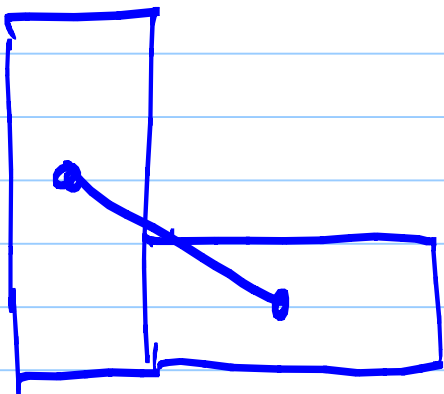

Center of mass of a triangular sheet

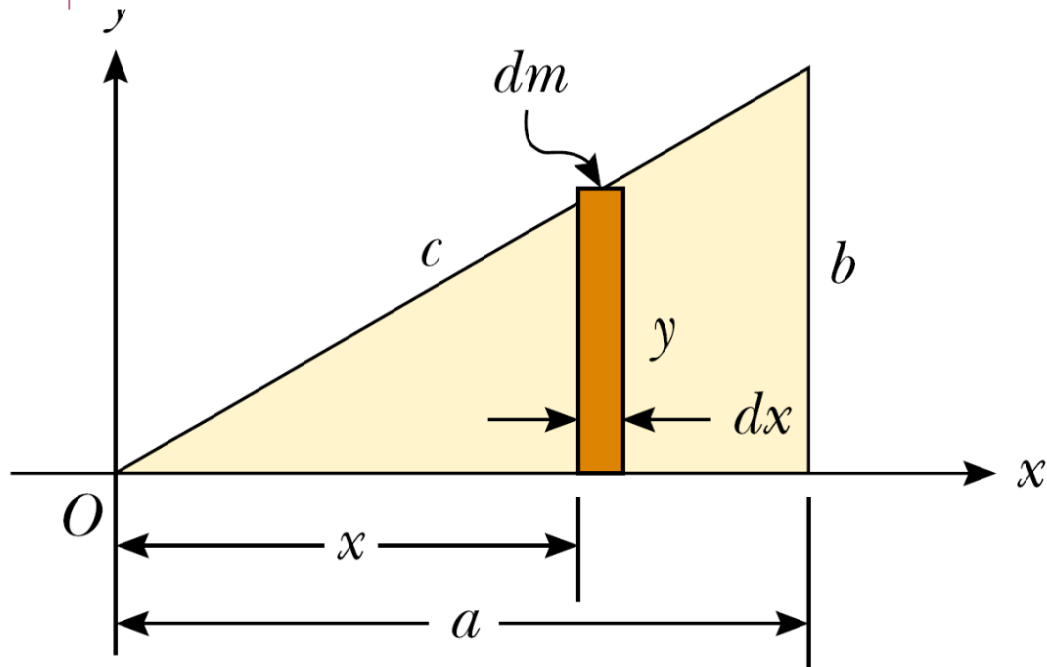

$$dm = \frac{\text{total mass}}{\text{total area}} \times \text{strip area.}$$

$$= \frac{M}{\frac{1}{2}ab} (y dx)$$

$$= \frac{2M}{ab} (y dx)$$

$$x_{cm} = \frac{1}{M} \int x dm = \frac{1}{M} \int_0^a \frac{2M}{ab} x y dx = \frac{2}{ab} \int_0^a x y dx$$

$$\frac{y}{x} = \frac{b}{a} \Rightarrow y = \left(\frac{b}{a}\right)x \quad \text{— eqⁿ of straight line}$$

$$x_{CM} = \frac{2}{a^2} \int_0^a x \left(\frac{b}{a}x\right) dx$$

$$= \frac{2}{a^2} \int_0^a x^2 dx = \frac{2}{3} a$$

$$y_{CM} = \frac{1}{3} b$$

$$\vec{r}_L = \frac{2}{3} a \hat{i} + \frac{1}{3} b \hat{j}$$

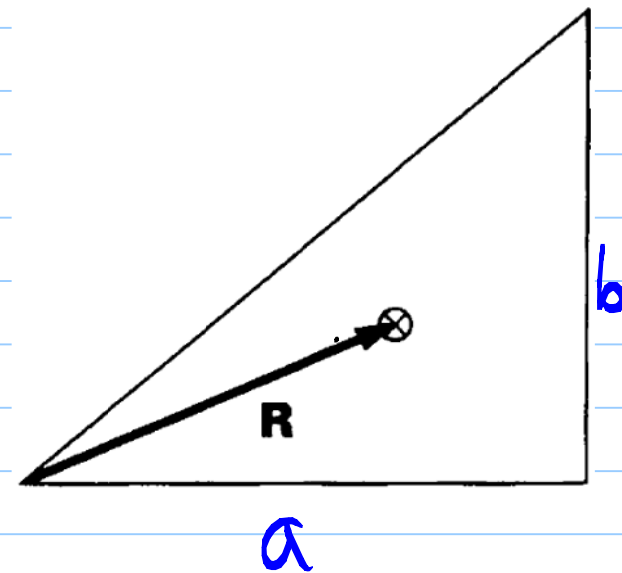
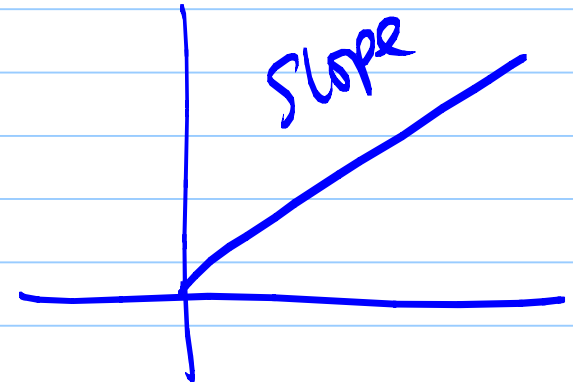

Center of mass of a hemisphere of radius R and mass M

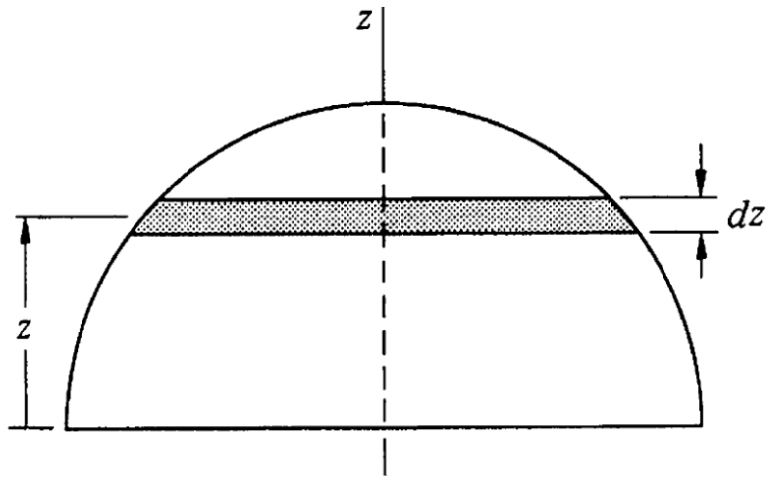

$$Z = \frac{1}{M} \int z dM$$

$$\Delta M = \rho dV = \frac{M}{V} dV$$

$$V = \frac{2}{3} \pi R^3$$

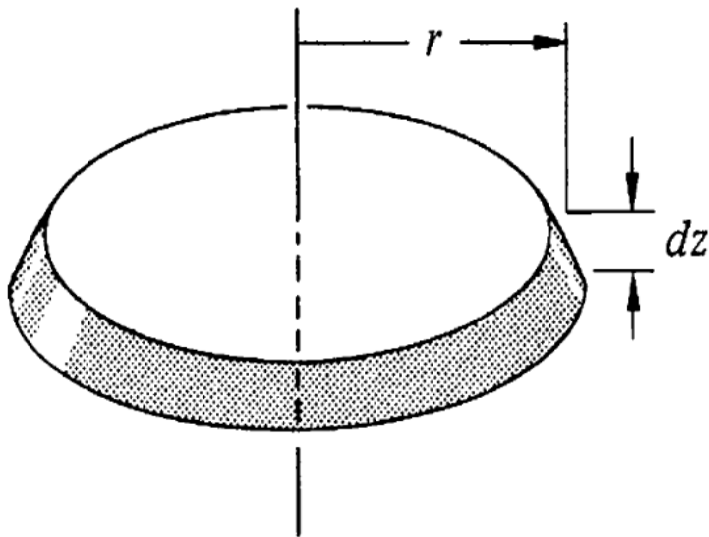

$$Z = \frac{1}{M} \int \frac{M}{V} z dV$$

$$= \frac{1}{V} \int_{z=0}^R \pi r^2 z dz$$

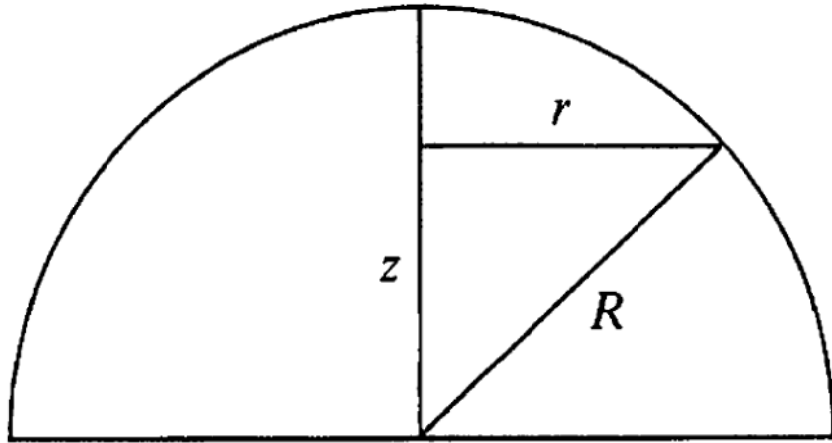

$$r^2 = R^2 - z^2$$

$$Z = \frac{\pi}{V} \int_0^R z(R^2 - z^2) dz$$

$$= \frac{\pi}{V} \left(\frac{1}{2} z^2 R^2 - \frac{1}{4} z^4 \right) \Big|_0^R$$

$$= \frac{\pi}{V} \left(\frac{1}{2} R^4 - \frac{1}{4} R^4 \right)$$

$$= \frac{\frac{1}{4} \pi R^4}{\frac{2}{3} \pi R^3}$$

$$= \frac{3}{8} R.$$

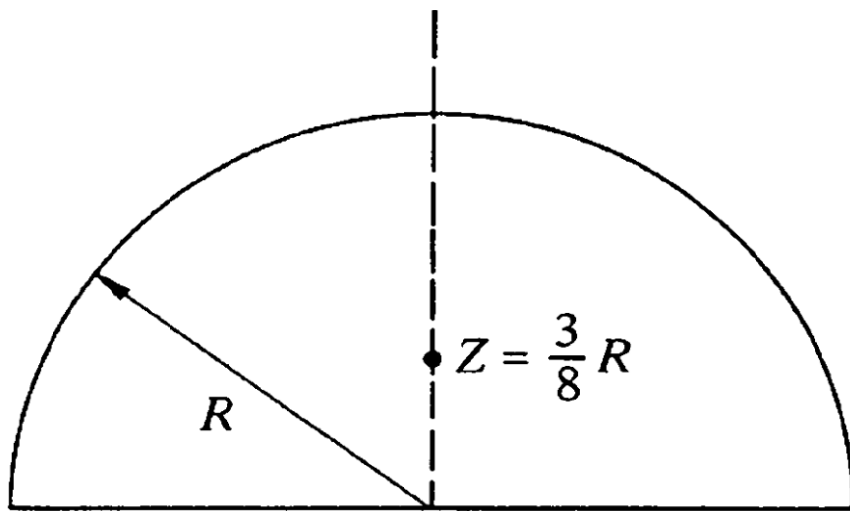

Impulse!

$$\vec{F} = \frac{d\vec{p}}{dt}$$

Differential!
form.

$$\int_0^t \vec{F} dt = \underbrace{\vec{p}(t) - \vec{p}(0)}_{\text{Change in momentum}}$$

Integral!
form.



Impulse

Small force — large time interval
large force — short time interval

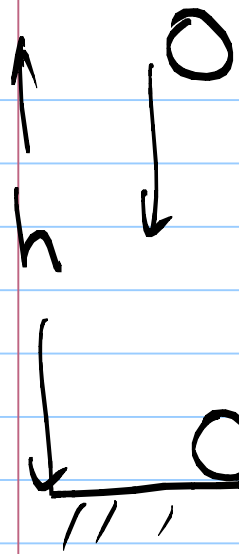

Impact time $\approx 2\text{ms}$

Elastic Collision

$$mv \downarrow \quad mv \uparrow \quad \equiv \quad 2mv = I$$

Weight
1 N

$$m = 0.1 \text{ kg}$$

$$h = 1.5 \text{ m}$$

$$v = 5.5 \text{ m/s}$$

$$I = 2mv = 1.1 \text{ kg m/s}$$

$$\langle F \rangle = \frac{I}{\Delta t} = \frac{1.1 \text{ kg m/s}}{2\text{ms}} = 550 \text{ N}$$

Momentum and flow of mass:

$$\vec{F} = \frac{d\vec{p}}{dt} \rightarrow \text{considered a set of particles}$$

$$I = \int_{t_a}^{t_b} \vec{F} dt = \vec{p}(t_b) - \vec{p}(t_a)$$

keep track of all the particles
within time interval t_a & t_b

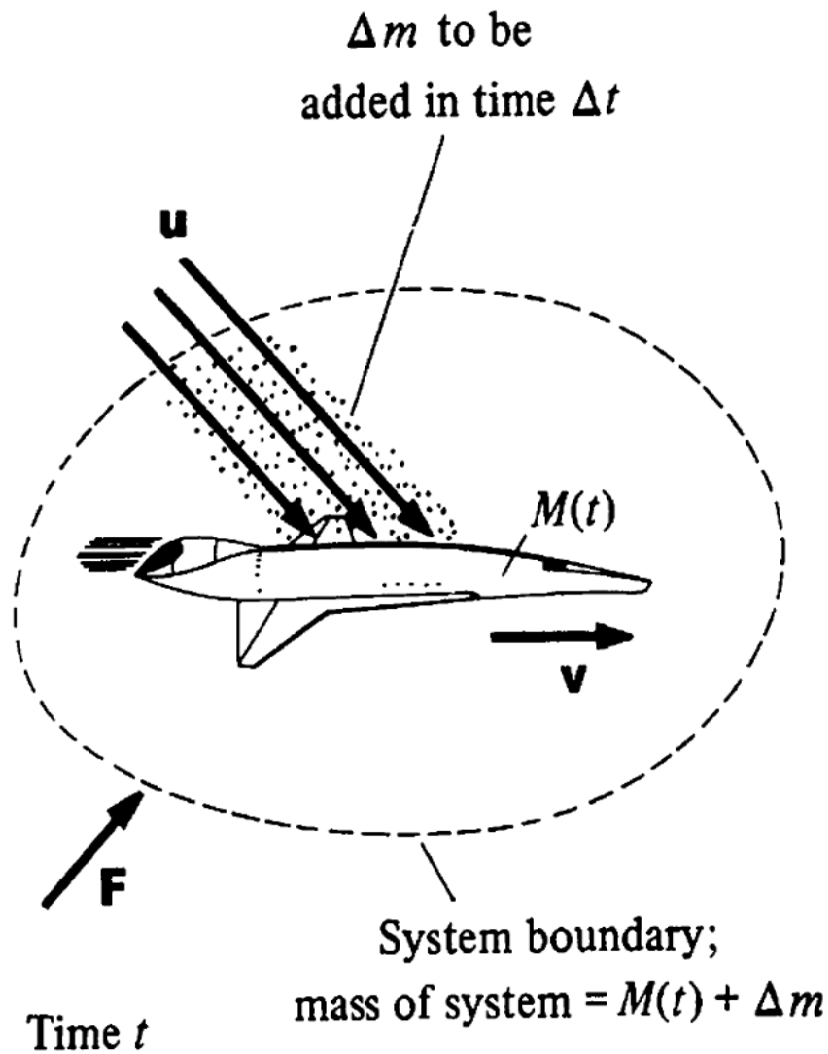

$F \rightarrow$ external force to keep the motion uniformly

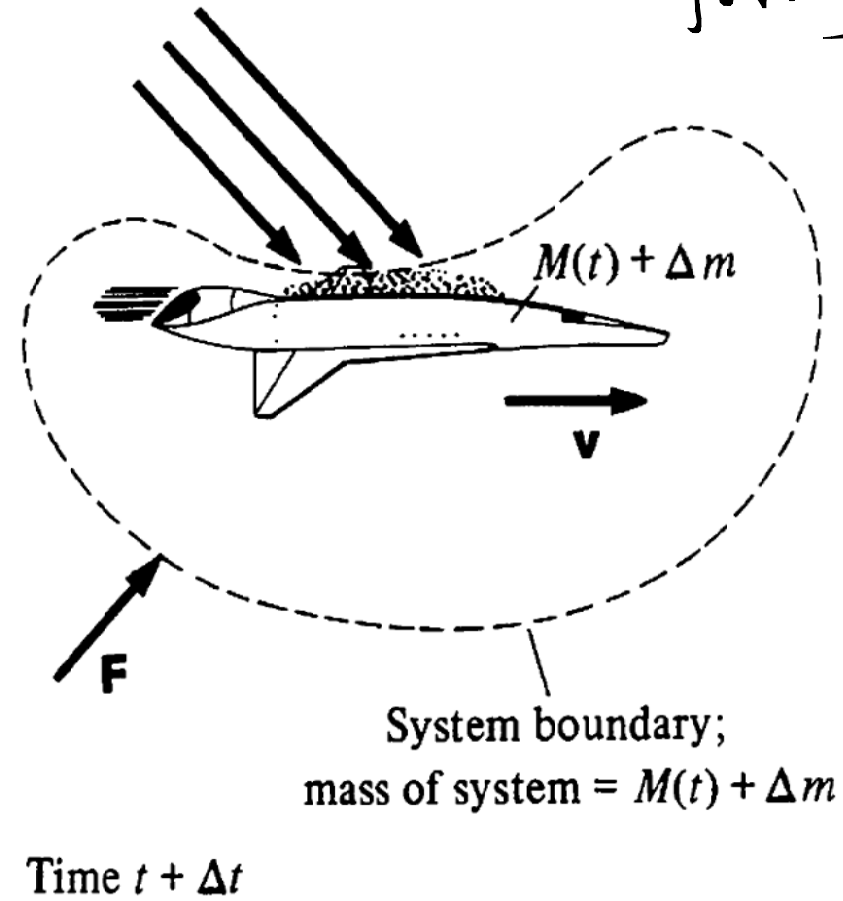

System consists of $M(t)$ and Δm

$$\vec{p}(t) = M(t)\vec{v} + (\Delta m)\vec{u} \quad \text{— initial momentum}$$

$$P(t+\Delta t) = M(t)\vec{v} + (\Delta m)\vec{v} \quad \text{— final momentum}$$

Change in momentum

$$\Delta \vec{p} = P(t+\Delta t) - P(t)$$

$$= (\vec{v} - \vec{u}) \Delta m$$

$$\frac{\Delta \vec{p}}{\Delta t} = (\vec{v} - \vec{u}) \frac{\Delta m}{\Delta t} \quad \text{at } \Delta t \rightarrow 0$$

$$\frac{d\vec{p}}{dt} = (\vec{v} - \vec{u}) \frac{dm}{dt} = \vec{F}$$

F can be either +ve or -ve. \rightarrow depends on $u \neq v$
if $u = v \Rightarrow F = 0 \rightarrow$ momentum constant.

Look back

$$F = \frac{d}{dt}(mv)$$

$$= \frac{dm}{dt} \vec{v} + m \frac{d\vec{v}}{dt}$$

$$v \rightarrow \text{constant} \Rightarrow \frac{dv}{dt} = 0$$

$$\vec{F} = \vec{v} \frac{dm}{dt}$$

However,

$$\vec{F} = (\vec{v} - \vec{u}) \frac{dm}{dt}$$

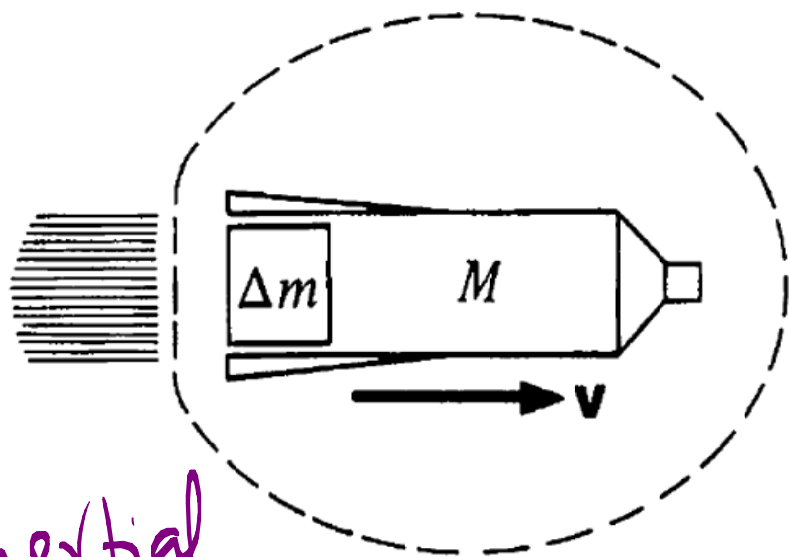

Time t

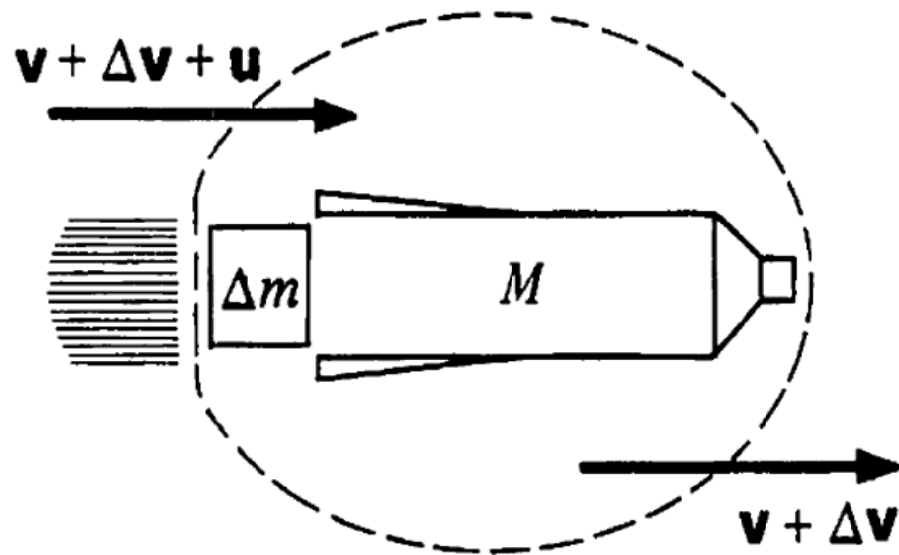

Time $t + \Delta t$

Inertial
frame

$$P(t) = (M + \Delta m) \vec{v}$$

$$P(t + \Delta t) = M (\vec{v} + \Delta \vec{v}) + \Delta m (\vec{v} + \Delta \vec{v} + \vec{u})$$

Change in momentum is

$$\Delta \vec{p} = \vec{p}(t + \Delta t) - \vec{p}(t)$$

$$= M \Delta \vec{v} + (\Delta m) \vec{u}$$

$$\frac{d\vec{p}}{dt} = m \frac{d\vec{v}}{dt} + \vec{u} \frac{dm}{dt}$$

Now $\frac{dm}{dt} = - \frac{dM}{dt}$

$$\vec{T} = \frac{d\vec{p}}{dt} = m \frac{d\vec{v}}{dt} - \vec{u} \frac{dM}{dt}$$

HW

No external force $\rightarrow \vec{T} = 0$ Rocket in free space!
Under Gravity
 $\vec{T} = Mg$

When $\vec{F} = 0$, No external force!

$$M \frac{d\mathbf{v}}{dt} = \mathbf{u} \frac{dM}{dt}$$

or

$$\frac{d\mathbf{v}}{dt} = \frac{\mathbf{u}}{M} \frac{dM}{dt}$$

$$\int_{t_0}^{t_f} \frac{d\mathbf{v}}{dt} dt = \mathbf{u} \int_{t_0}^{t_f} \frac{1}{M} \frac{dM}{dt} dt$$

$$= \mathbf{u} \int_{M_0}^{M_f} \frac{dM}{M}$$

$$\mathbf{v}_f - \mathbf{v}_0 = \mathbf{u} \ln \frac{M_f}{M_0}$$

$$= -\mathbf{u} \ln \frac{M_0}{M_f}$$

Rocket equation!

Under gravity! $\vec{F} = m\vec{g}$

$$\vec{M}\vec{g} = M \frac{d\vec{v}}{dt} - \vec{v} \frac{dM}{dt}$$

\vec{v} and \vec{g} are in same direction!

$$\frac{d\vec{v}}{dt} = \frac{v}{m} \frac{dM}{dt} + g$$

Integrate!

$t_f \rightarrow$ Burn time!

$$v_f - v_0 = u \ln \frac{M_f}{M_0} + g(t_f - t_0)$$

$$\text{at } v_0 = 0, t_0 = 0 \quad | \quad v_t = u \ln \left(\frac{M_0}{M_f} \right) - g t_f$$

Initially car is at rest!

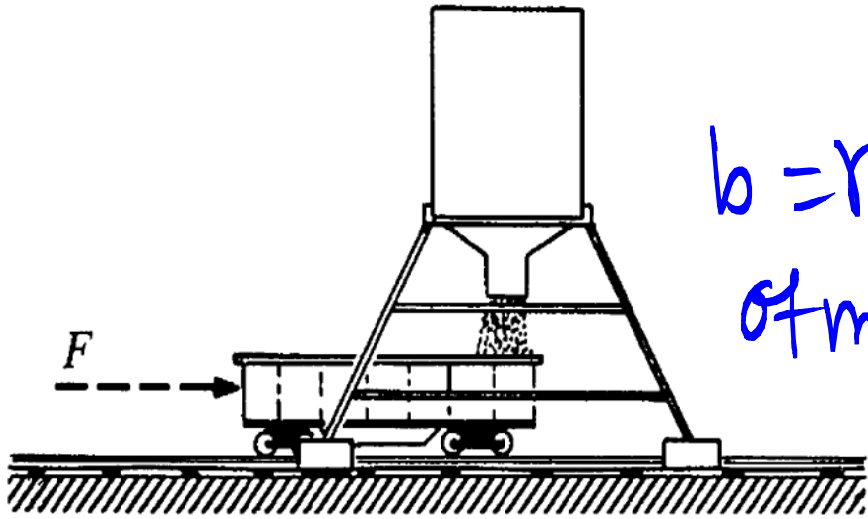

$b = \text{rate of mass flow}$

$$\vec{F}t = \vec{p}_f - \vec{p}_i$$

$$\vec{p}_f = (M + bt)v$$

$$\vec{p}_i = 0$$

$$(M + bt)v = Ft$$

$$v = \frac{Ft}{(M + bt)}$$

$$m = bt$$

$$t = \frac{m}{b}$$